

MONITOUCH PLUS EXPRESS

Application Example for Connecting Various Measuring Devices

Issue No. 22
2010

There are various advantages of connecting MONITOUCH with various measuring devices.

- It is possible to collect the measured data at low cost as MONITOUCH can be directly connected with various measuring devices.
- Drastic reduction of man-hour is possible as a measuring result can be recorded on PC at the time of the measuring completion.
- Because a measuring result, which has been sent from the measuring device, is directly recorded, there is no need to worry about the misentry of the inspection result.
- It is possible to prevent nonstandard product failure by real-time quality check at the factory floor.

Quality Control Support System

System that collects the measured data automatically and analyzes the variability/trend of the quality

[Traditional Way] Measures the data and write the result on a paper. Report is made based on the entered information.

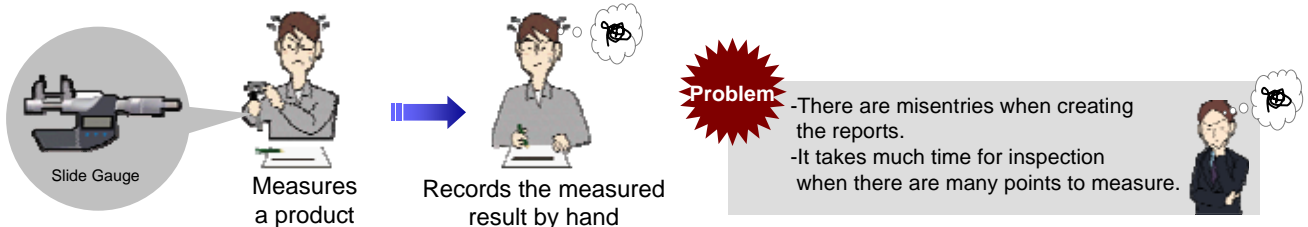

MONITOUCH + V-Server makes the inspection operation easier!

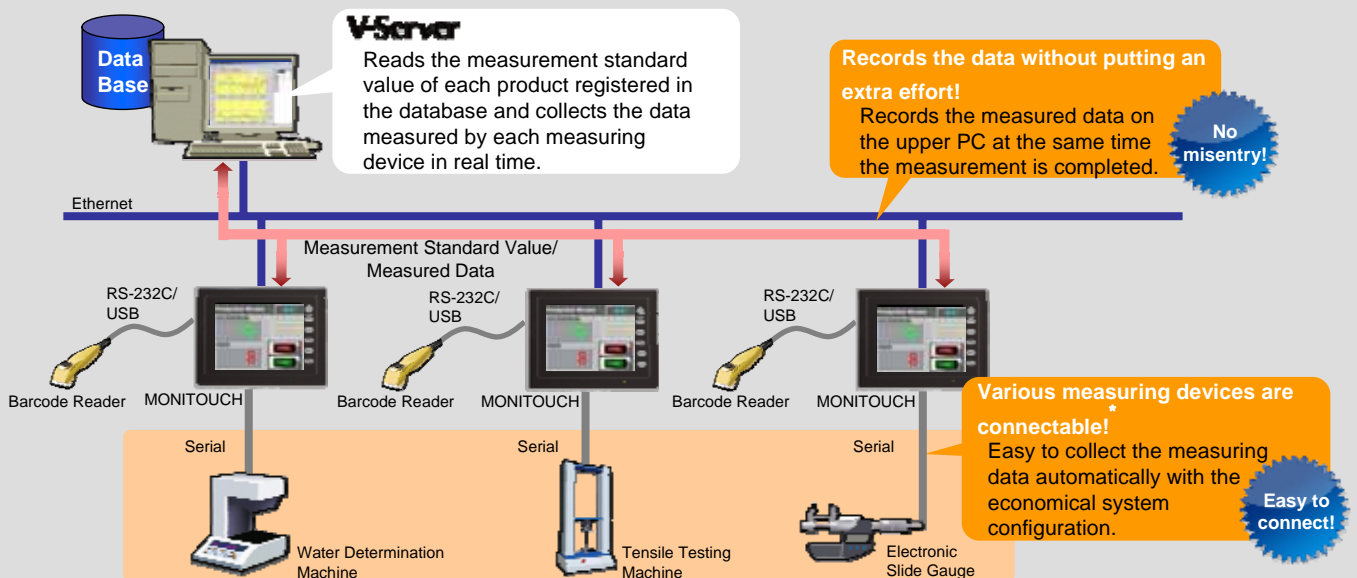

[Feature]

- 1) By reading the information such as a product code and an operator code, it is possible to save time for registration as well as it prevents the misentry.
- 2) Reading the measurement standard value and writing the measured data from/to the database are available.
- 3) It is possible to prevent a careless mistake since right and wrong of the measured data can be automatically judged based on the measurement standard value.

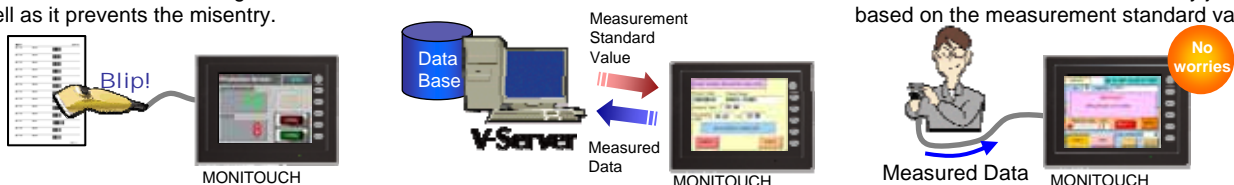

* Please contact Hakko sales representative regarding the connectable devices.

Stronger support for quality control is available with combination of JOYSPC by JTE!

Trend of the quality data can be grasped in real time.

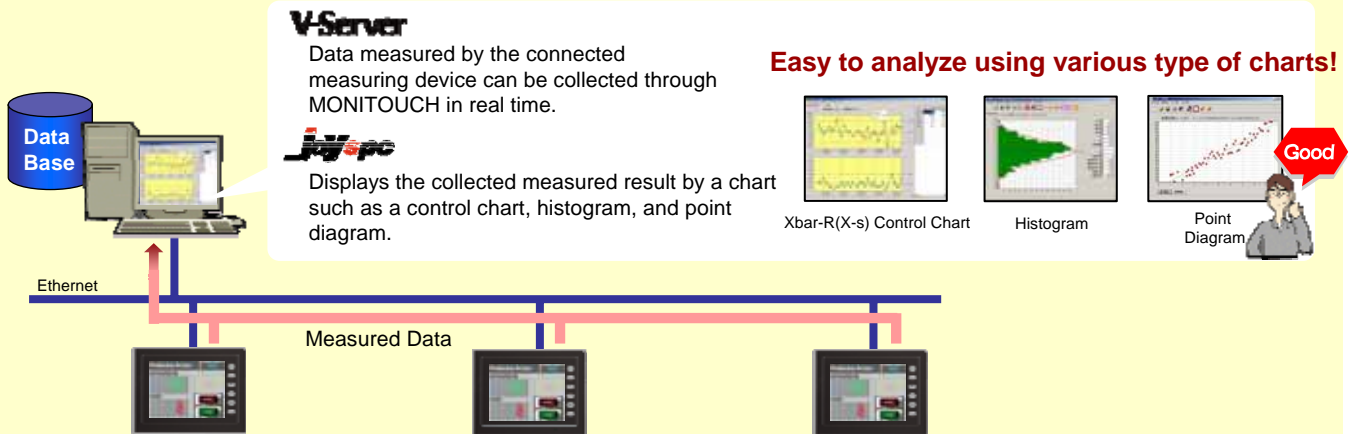

Quality control information can be browsed on the Web.



Please contact the following for more information regarding **JOYSPC**.

JT Engineering Inc. (JTE)

1-17-7 Yokogawa, Sumida-ku, Tokyo
130-8603 Japan
TEL:+81-3-5610-7605/FAX:+81-3-5610-7609



Free version upgrade of the configuration software V-SFT-5



The configuration software (upgraded version) can be downloaded from the following website.

Website:

<http://www.hakko-elec.co.jp/jp/download/09vsft5/index.php>